



SINGLE DRUM SOIL COMPACTOR | JCB 116D

Operating weight: 11350kg Engine power: 85kW (114hp) Drum width: 2100mm



PRODUCTIVITY MAXIMISED.

THE JCB 116D IS DESIGNED TO GIVE YOU ULTIMATE PRODUCTIVITY. EQUIPPED WITH AN INNOVATIVE DIESELMAX ENGINE, IT PROVIDES REDUCED LIFE CYCLE COSTS AND FUEL CONSUMPTION.

Built for efficiency.

1 Maximum compaction performance is achieved through the combination of high front weight ratio and heavy duty dynamic vibration system.

2 Static Linear load of over 30kg/cm plus class leading 256kN of dynamic centrifugal force and a high amplitude of 1.8mm combine to create class-leading compaction performance.

3 The high-torque, high-efficiency JCB 444 engine requires only 2000rpm to power the JCB 116D with outstanding fuel efficiency and a very low noise level of only 104 dB.

4 With the optional Pad Foot (PD) shell kit for added versatility the JCB 116D can be used either as a Smooth Drum machine for granular and non-cohesive materials or as a pad Foot machine for sticky, clay type soils.



QUALITY, RELIABILITY AND DURABILITY.

SOIL COMPACTORS HAVE TOUGH LIVES, WHICH IS WHY WE'VE DESIGNED AND BUILT THE JCB 116D TO BE AS ROBUST AS THEY CAN BE. PRODUCTIVITY AND UPTIME ARE MAXIMISED ACCORDINGLY.

Quality at its best.

1 All of our soil compactors are subjected to a rigorous 2-hour hot test to ensure they're ready for trouble-free use from day one.

2 Advanced manufacturing and assembly processes are used to ensure maximum quality components and precision fit.

3 The robust maintenance-free centre joint has been the trusted mainstay of JCB's soil roller compactors and it continues to offer reduced servicing costs and increased durability on this machine too.

4 To prove our JCB DIESELMAX engines' durability, we have done 110,000 hours of testing with over 70 different machines across the toughest applications and environments.

5 JCB's pre-loaded shock mounts ensure precise control of pre-load in the drum isolation mounts to give longer life as well as consistent isolation performance

6 Heavy duty frame and beams have been designed by advanced FEA techniques to deliver structural durability which has been proven by extensive field trials and accelerated life test methods.



COMFORTABLY SUPERIOR.

TO GET THE MOST OUT OF YOUR JCB 116D, IT'S CRUCIAL THAT OPERATORS CAN PERFORM THEIR JOB EFFICIENTLY AND IN ALL-DAY COMFORT. AS SUCH, BOTH MACHINES ARE DESIGNED TO OFFER A GREAT WORKING ENVIRONMENT.

Designed for ease of use.

1 Operators can get to work quickly on a JCB 116D because of the intuitive, easy-to-use and controls, all laid ergonomically and using industry standard identification.

2 Ergonomically designed and positioned steering wheel and console offer fatigue-free operation.

3 Optional built in compaction meter, placed ergonomically for added efficiency, comfort and ease of use.

4 Fatigue-free all-day operation comes as standard: these machines are designed to offer very low noise levels. What's more, by isolating the operator stand with 4 heavy duty rubber mounts, we've ensured class-leading low vibration levels too.

5 The Drum isolation system has been specially developed and tested to give maximum transfer of energy and dynamic forces into the ground whilst isolating the machine frame and operator.



 The picture can't be displayed.

2

SERVICING, SAFETY AND SECURITY.

WE UNDERSTAND THAT A SOIL COMPACTOR IS ONLY PROVIDING ULTIMATE PRODUCTIVITY AS LONG AS IT'S WORKING ON-SITE FOR YOU. THAT'S WHY WE'VE DESIGNED THE JCB 116D TO OFFER THE MAXIMUM UPTIME WITH SIMPLE, MINIMISED SERVICING.

Routine maintenance.

1 JCB 116D is designed for ease of servicing. All the daily checks can be done from ground level on one side of the machine.

100% access to all hydraulic and engine filters, fuel filters and injection system from ground level.

2 A wide opening rear bonnet gives fast access to the engine compartment. The Bonnet and components fit well within the profile of the rear chassis and are protected by it.

3 Assured parts supply: JCB's robust Global logistics and supply chain management organisation Ensures rapid delivery of spare parts where ever the machine may be.

Safety and security.

4 Standard LiveLink assures JCB 116D security and operating condition are always known.

5 Lockable diesel fill points are out of sight under the engine cover to prevent fuel theft or vandalism. Best in class visibility from both the front and rear of the machine.

Towing pump for manual drive brake release.

Waterproof control panel (IP 67/69).



1



3



4

LIVELINK, WORK SMARTER.

JCB LIVELINK IS AN INNOVATIVE SOFTWARE SYSTEM THAT LETS YOU MONITOR AND MANAGE YOUR MACHINES REMOTELY - ONLINE, BY EMAIL OR BY MOBILE PHONE.

Productivity and cost benefits - Machine location information can improve fleet efficiency and you may even enjoy reduced insurance costs courtesy of the added security that LiveLink brings.

**Note: Please consult your local dealer for LiveLink availability*



Maintenance benefits - Accurate hours monitoring, maintenance history records, critical machine alerts and service alerts improve maintenance planning.

Security benefits - Real-time geofencing lets you set operating zones and curfew alerts that tell you when your machinery outside of pre-determined times. Location information helps you store machines safely.

VALUE ADDED.

JCB'S WORLDWIDE CUSTOMER SUPPORT IS FIRST CLASS. WHATEVER YOU NEED AND WHEREVER YOU ARE, WE'LL BE AVAILABLE QUICKLY AND EFFICIENTLY TO HELP MAKE SURE YOUR MACHINERY IS PERFORMING TO ITS FULL POTENTIAL.



1 Our Technical Support Service provides instant access to factory expertise, day or night, while our Finance and Insurance teams are always on hand to provide fast, flexible, competitive quotes.

JCB Assetcare offers comprehensive extended warranties and service agreements, as well as service-only or repair and maintenance contracts. Irrespective of what you opt for, our Maintenance teams around the world charge competitive labour rates, and offer non-obligation quotations as well as fast, efficient insurance repair work.



2 The global network of JCB Parts Centres is another model of efficiency; with 16 regional bases, we can deliver around 95% of all parts anywhere in the world within 24 hours. Our genuine JCB parts are designed to work in perfect harmony with your machine for optimum performance and productivity.

STATIC DIMENSIONS

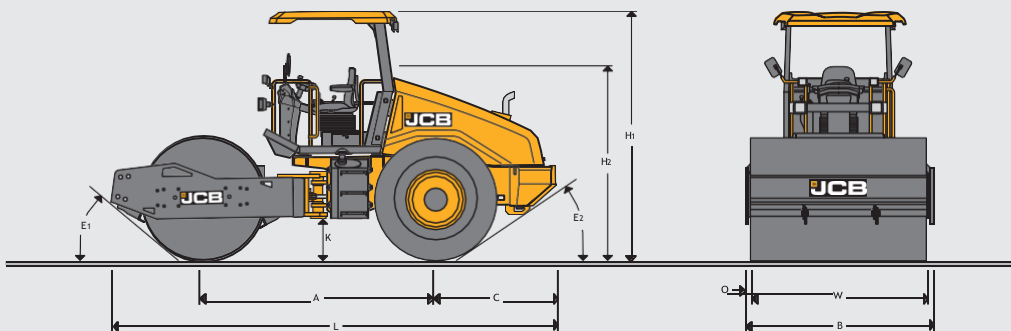

STATIC DIMENSIONS

A	Wheelbase	mm	2846
B	Overall width	mm	2240
C	Axle to rear face	mm	1517
E1	Front departure angle	degrees	39
E2	Rear departure angle	degrees	34
H1	Total travel clearance	mm	2995
H2	Height to top of seat (unfolded)	mm	2280
K	Ground clearance	mm	443
L	Total travel length	mm	5473
O	Overhang	mm	70
W	Drum width	mm	2100
	Drum diameter (smooth drum)	mm	1500
	Inner diameter (padfoot drum)	mm	1500
	Outer diameter (padfoot drum)	mm	1680
	Drum thickness	mm	28

ENGINE

Manufacturer	JCB		
Model	JCB DIESELMAX TCA-85		
Total displacement	cm ³	4399	
Gross power	kW (hp)	85 (114)	
Operating speed / Rated speed	rpm	2000 / 2200	
Starting device	Electric motor		
Air cleaner	Two stage dry type		
Fuel filter	Cartridge		
Emission	Tier III		

SERVICE CAPACITIES

Fuel	litres	300
Engine oil	litres	14
Hydraulic oil	litres	80
Coolant / System	Alternator	21

OPERATING DATA

Operating weight	kg	11350	
Max. operating weight	kg	13200	
Operating axle load front / rear	kg	6450 / 4900	
Vibration stage		1	2
Exciter frequency	Hz (vpm)	32 (1920)	36 (2160)
Nominal amplitude	mm	1.8	0.8
Centrifugal force	kN	256	147
Static linear load	kg/cm	30.7	
Working speed (forward / reverse) max.	km/h	5	
Travel speed (forward / reverse) max.	km/h	10.5	
Steering lock angle	degrees	35	
Oscillation angle	degrees	15	
Inner turning radius	m	3.4	
Tyres		23.1-26/8PR	
Number of padfeet (optional PD shell)		132	
Height of padfeet (optional PD shell)		90	
Gradeability up to (drum drive)	degrees	28.5 / 55	

ELECTRICAL SYSTEM

Voltage	V	12
Battery capacity	Ah	120
Alternator	V	90

PROPULSION

Infinitely variable hydrostatic direct drive by variable displacement motor on rear axle and drum, limited slip axle.

EXCITER DRIVE

Electronically-controlled hydrostatic direct drive on drum.

EXCITER

Dual-amplitude circular exciter with overturning weights.

STEERING SYSTEM

Servo assisted centre articulation with automatic oscillation.

BRAKING SYSTEM

Service brake: Hydrostatic propulsion system

Parking brake: Hydraulically-released multi-disk brake on rear axle and drum drive

Emergency brake: Electronically-controlled, disk brake, on rear axle and drum drive.

INDICATORS AND SWITCHES

Engine RPM with hour meter, fuel gauge, engine temperature gauge, indicators for engine oil pressure, battery charging current, hydraulic oil and air filter condition, parking brake, neutral position control lever, switches for speed range selection, frequency, acoustic back-up alarm, four working lights, head lamps, turn signal, hazard-warning lights.

OPTIONS

ROPS & FOPS cab, ROPS & FOPS canopy, Compatronic compaction measurement device, padded foot drum shell.



ONE COMPANY, OVER 300 MACHINES.

Your nearest JCB dealer

Single Drum Soil Compactor JCB 116D

Operating weight: 11350kg Engine power: 85kW (114hp) Drum width: 2100mm

JCB Sales Limited, Rocester, Staffordshire, United Kingdom ST14 5JP.

Tel: +44 (0)1889 590312 Email: salesinfo@jcb.com

Download the very latest information on this product range at: www.jcb.com

©2009 JCB Sales. All rights reserved. No part of this publication may be reproduced, stored in a retrieval system, or transmitted in any form or by any other means, electronic, mechanical, photocopying or otherwise, without prior permission from JCB Sales. All references in this publication to operating weights, sizes, capacities and other performance measurements are provided for guidance only and may vary dependant upon the exact specification of machine. They should not therefore be relied upon in relation to suitability for a particular application. Guidance and advice should always be sought from your JCB Dealer. JCB reserves the right to change specifications without notice. Illustrations and specifications shown may include optional equipment and accessories. All images are correct at time of print. The JCB logo is a registered trademark of J.C. Bamford Excavators Ltd.

